

B.Tech II Year I Semester (R13) Supplementary Examinations June 2015

ENGINEERING GRAPHICS

(Common to EEE, CSE, IT and EIE)

Time: 3 hours

Max. Marks: 70

(Answer all five units, 5 X 14 = 70 Marks)
All questions carry equal marks

UNIT – I

- 1 A fixed point is 75 mm from a fixed straight line. Draw the locus of a point P moving such a way that its distance from the fixed straight line is (i) twice its distance from the fixed point. (ii) equal to its distance from the fixed point. Name the curves.

(OR)

- 2 A circle of 50 mm diameter rolls on the circumference of another circle of 175 mm diameter and outside it; trace the locus of a point on the circumference of the rolling circle for one complete revolution. Name the curve draw a tangent and normal to the curve at a point 125 mm from the centre of the directing circle.

UNIT – II

- 3 The distance between the projectors of two points. A and B is 70 mm, point A is 10 mm above HP and 15 mm in front of VP. Point B is 50 mm above HP and 40 mm in front of VP. Find the shortest distance of between A and B. Measure true inclination of the line AB with HP and VP.

(OR)

- 4 The mid-point of straight line AB is 60 mm above H.P and in front of V.P. The line measures 80 mm long and inclined at an angle of 30° to H.P and 45° V.P. Draw its projections.

UNIT – III

- 5 (a) A square lamina of 40 mm is perpendicular to both planes. Draw projections with lamina is 25 mm above HP and 40 mm in front of VP.
(b) A rectangular plate of negligible thickness and having 40 × 60 mm dimensions is perpendicular to both planes. Its longer side is perpendicular to V.P and in H.P and 20 mm in front of V.P. Draw its projections.

(OR)

- 6 (a) Pentagonal prism base 30 mm side and axis 60 mm long has an edge of its base in H.P axis is inclined at 45° to ground and parallel to V.P.
(b) Projection of a cone, base 75 mm diameter and axis 100 mm long lying on H.P with its axis parallel to V.P and inclined at 30° to H.P.

UNIT – IV

- 7 A pentagonal pyramid side of base 36 mm and height 64 mm rests on its base on H.P with one of its base sides parallel to V.P. A section plane perpendicular to V.P and inclined at 30° to H.P cuts the pyramid, bisecting its axis. Draw the development of the truncated pyramid.

(OR)

- 8 A pentagonal prism of base side 30 mm and axis length is 60 mm is resting on H.P on its base with a side of base is parallel to V.P it is cut by a plane inclined at 35° to H.P and perpendicular V.P and meet the axis at a distance 35 mm from the base. Draw the development of the lower portion of the prism.

Contd. in page 2

Code: 13A03304

UNIT - V

- 9 Draw the elevation, plan and left and right views of the bracket shown in the picture below (dimensions in mm).

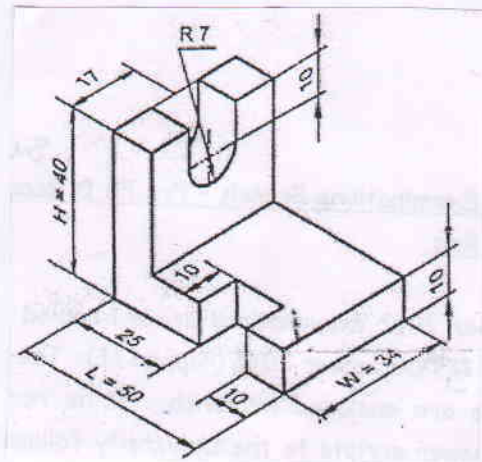

(OR)

- 10 Draw the elevation, plan and right views of the bracket shown in picture below (dimensions in mm).

