

Code: 13A03303

R13

B.Tech II Year I Semester (R13) Supplementary Examinations June 2016

MACHINE DRAWING
(Mechanical Engineering)

Time: 4 hours

Max. Marks: 70

All answer should be on the drawing sheet only
Answers on the drawing sheet only will be valued
First angle projections to be adopted

Section – I

Answer any two of the following (2 × 4 = 08 Marks)

- 1 Sketch the conventional representation of the following:
 - (a) Tin.
 - (b) Marble.
 - (c) Wax.
 - (d) Aluminium.
- 2 Draw the conventional representation of Spur gear and tension spring.
- 3 Sketch the following thread profiles for nominal size of 30 x 3 mm using suitable scale:
 - (a) B.S.W thread.
 - (b) Worm thread.

Section – II

Answer any two of the following (2 × 10 = 20 Marks)

- 4 Sketch any three types of machine screws of 10 mm diameter.
- 5 Sketch the sectional front view and side view of a protected flanged coupling indicating proportions to connect two shafts each of diameter 30 mm.
- 6 Draw sectional front view and top view of the double riveted, double strap chain butt joint of plates of thickness 10 mm.

Section – III

Answer the following (1 × 42 = 42 Marks)

- 7 The details of an Eccentric are shown in figure below. Assemble the parts and draw:
 - (a) Half sectional view from the front with top half in section.
 - (b) View from the right and view from above.

Contd. in page 2

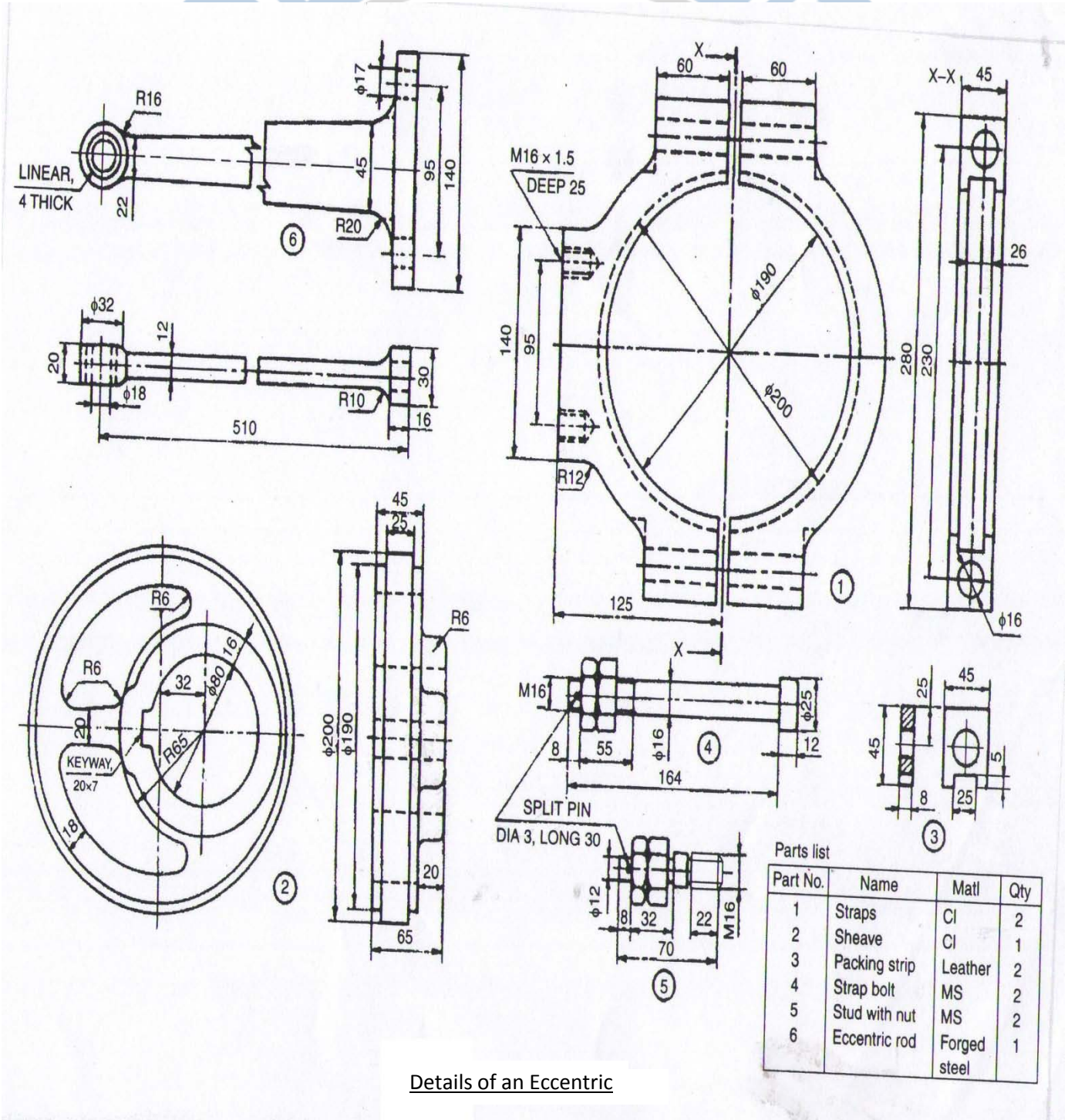

Details of an Eccentric
