

**ENGINEERING GRAPHICS**  
(Common to EEE, CSE, IT and EIE)

Time: 3 hours

Max. Marks: 70

(Answer all five units, 05 X 14 = 70 Marks)  
All questions carry equal marks

\*\*\*\*\*

**UNIT – I**

1 Draw the locus of a point 'p' moving so that the ratio of the distance from a fixed point 'f' to its distance from a fixed straight line DD' is  $\frac{3}{4}$  point P is at a distance of 70 mm from DD'. Also draw a tangent and normal to the curve.

**OR**

2 Construct an epicycloid generated by a rolling circle of diameter 50 mm and a directing circle of diameter 150 mm. Draw the tangent and normal to the curve at any point on the epicycloid.

**UNIT – II**

3 One end P of a line PQ, 55 mm long is 35 mm in front of the VP and 25 mm above the HP. The line is inclined at  $40^\circ$  to the HP and  $30^\circ$  to the VP. Draw the projections of line PQ.

**OR**

4 A line AB has its end A in the HP and 40 mm in front of VP. Its front view is inclined at  $50^\circ$  to XY and has a length of 70 mm. The other end B is in the VP. Draw its projections.

**UNIT – III**

5 A rectangular plate of side 70 x 40 mm has its shorter edges in the VP inclined of  $40^\circ$  to the HP. Draw its top view if its front view is a square of side 40 mm.

**OR**

6 A cylinder of diameter 30 mm and axis length 50 mm is resting on the HP on a point so that its axis is inclined at  $45^\circ$  to the HP and parallel to the VP. Draw its top and front views.

**UNIT – IV**

7 A hexagonal prism of base side 30 mm and axis length 70 mm rests on one of its ends on the HP with two base sides parallel to the VP. It is cut by a plane perpendicular to the VP and inclined at  $30^\circ$  to the HP. The cutting plane meets the axis at 30 mm from the top. Draw the front view, sectional top view and the true shape of the section.

**OR**

8 A pentagonal pyramid of base side 25 mm and height 60 mm is resting vertically on its base on the ground with one of the sides of the base parallel to VP. It is cut by a plane perpendicular to VP and parallel to HP at a distance of 25 mm above the base. Draw the development of the lateral surface of the frustum of the pyramid. Also show the top of the cut surface.

Contd. in page 2

UNIT - V

9 Draw the front view and top view of the object given below. (All dimensions in mm).

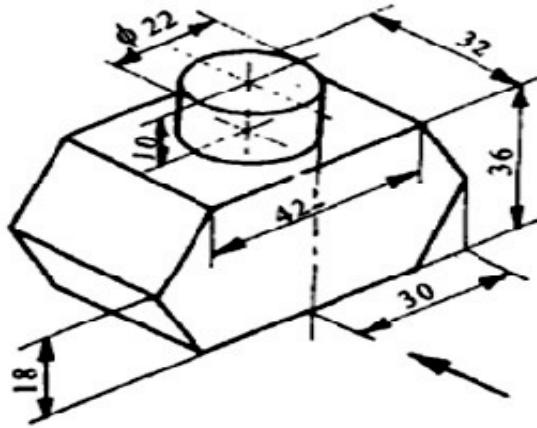

OR

10 Draw the Conversion of Orthographic Views to Isometric Views of given object. (All dimensions in mm).

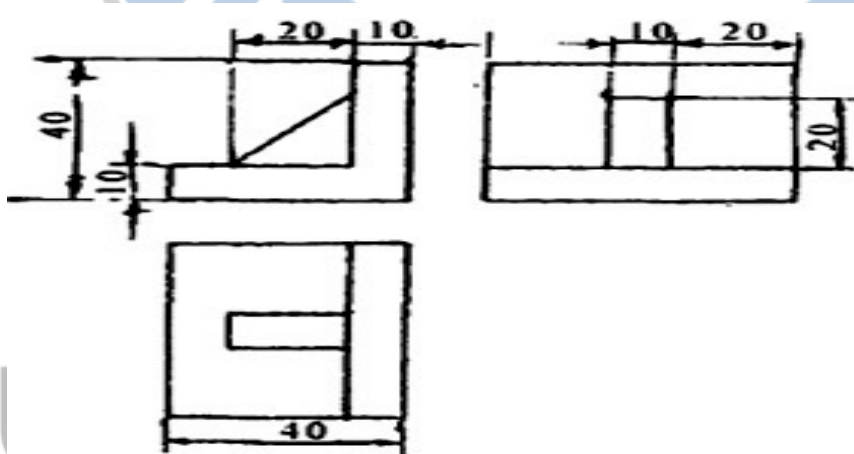

\*\*\*\*\*