

**Code: 13A03304**

B.Tech II Year I Semester (R13) Regular &amp; Supplementary Examinations December 2015

**ENGINEERING GRAPHICS**  
(Common to EEE, CSE, IT and EIE)

Time: 3 hours

Max. Marks: 70

(Answer all five units, 05 X 14 = 70 Marks)

All questions carry equal marks

\*\*\*\*\*

**UNIT - I**

1 A ball thrown from the ground level reaches a maximum height of 5 m and travels a horizontal distance of 12 m from the point of projection. Trace the path of the ball.

**OR**

2 A circle of 80 mm diameter rolls on the circumference of another circle of 120 mm radius and inside it. Draw the locus of the point P on the circumference of the rolling circle for one complete revolution of it. Name the curve & draw tangent and normal to the curve at a point 100 mm from the centre of the bigger circle.

**UNIT - II**

3 Draw the orthographic projections of the following points:

- (a) Point P is 30 mm above H.P and 40 mm in front of VP.
- (b) Point Q is 25 mm above H.P and 35 mm behind VP.
- (c) Point R is 32 mm below H.P and 45 mm behind VP.
- (d) Point S is 35 mm below HP and 42 mm in front of VP.
- (e) Point T is in HP and 30 mm is behind VP.
- (f) Point U is in VP and 40 mm below HP.
- (g) Point V is in VP and 35 mm above HP.
- (h) Point W is in HP and 48 mm in front of VP.

**OR**

4 A line AB, 90 mm long, is inclined at  $30^\circ$  to the HP. Its end A is 12 mm above the HP and 20 mm in front of the VP. Its FV measures 65 mm. Draw the TV of AB and determine its inclination with the VP.

**UNIT - III**

5 An isosceles triangular lamina has base 25 mm long and altitude 35 mm. It is so placed on HP such that in the front view it is seen as an equilateral triangle of 25 mm sides with the side that is parallel to VP is inclined at  $45^\circ$  to HP. Draw its top and front views. Also determine the inclination of the lamina with reference plane.

**OR**

6 A cone of 50 mm base diameter and 60 mm axis length rests on HP on one of its generators. Draw its projections when the axis is inclined to VP at 30 degrees.

Contd. in page 2

## UNIT - IV

- 7 A hexagonal pyramid of side of base 40 mm and height of axis 110 mm is resting on one of its inclined vertical surfaces on H.P. such that its axis remains parallel to the V.P. It is cut by a cutting plane which is inclined at an angle  $45^\circ$  with H.P. and bisecting the axis of the pyramid. Draw front view, sectional top view.

OR

- 8 A pentagonal prism, 30 mm base side and 50 mm axis is standing on HP on its base with one side of the base perpendicular to VP. It is cut by a section plane inclined at  $45^\circ$  to the HP, through mid-point of the axis. Draw FV, Sectional TV & Sectional Side view. Also draw true shape of section and Development of surface of remaining solid.

## UNIT - V

- 9 Figure shown below isometric view, of a simple machine component. Draw its following Orthographic views and dimension them.

- (a) Front View.  
(b) Top View.  
(c) R.H.S. View.

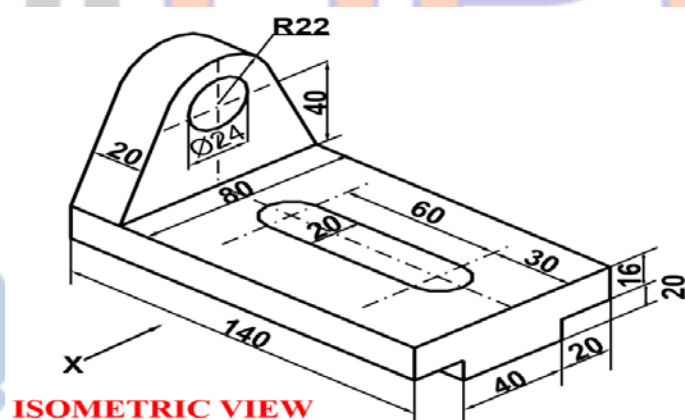

ISOMETRIC VIEW

OR

- 10 Draw the isometric view of the object shown in figure below, using orthographic views.

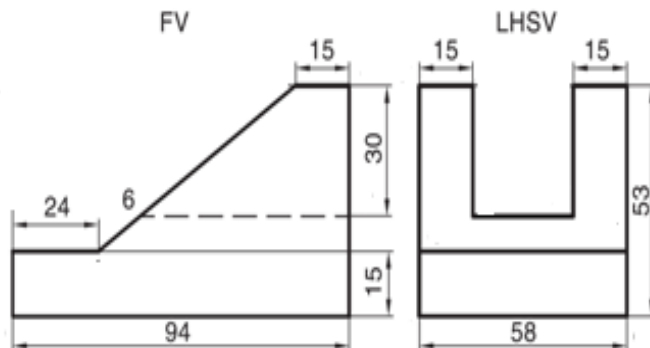

\*\*\*\*\*