

R16

Code No: 132AE

JAWAHARLAL NEHRU TECHNOLOGICAL UNIVERSITY HYDERABAD

B.Tech I Year II Semester Examinations, April - 2018

ENGINEERING GRAPHICS

(Common to CSE, IT, ETM)

Time: 3 hours

Max. Marks: 75

Answer all five questions
All questions carry equal marks

- 1.a) Draw the curve traced by a point on the circumference of a circle of 50 mm diameter, which rolls on a straight line for one complete revolution. Name the curve.
- b) Construct a scale of 1:5 to show decimeters and centimeters and long enough to measure up to 1m. Show a distance of 6.3 dm on it. [8+7]

OR

- 2.a) Construct an ellipse inside a rectangle of dimensions 70 mm × 100 mm.
- b) Construct a diagonal scale of 1:6 to show decimeters and centimeters and millimeters long enough to measure up to 1m. Show a distance of 5.31 dm on it. [7+8]
- 3.a) A 75 mm long line PQ is inclined at an angle of 30° to the V.P. The end P is on the H.P. and 30 mm in front of the V.P. The end Q is 50 mm above the H.P. Draw the projections of the line.
- b) A square lamina with a 40 mm side has its surface parallel to and 30 mm in front of the V.P. Draw the projections when one of its sides is inclined at 30° to the H.P. [7+8]

OR

- 4.a) A 75 mm long line PQ, has the end P at 25 mm above the H.P. and 10 mm in front of the V.P. The lengths of the front and top views are 60 mm. Draw the projections of the line.
- b) A rectangular plate of 60 mm and 40 mm sides rests on the H.P. on the shortest edge, with its surface perpendicular to the V.P., such that the centre of the plate lies 20 mm above the H.P. and 30 mm in front of the V.P. Draw the projections [7+8]

5. A pentagonal pyramid, having a base with a 30 mm side and a 60 mm long axis, has one of the edges of the base in the H.P. The solid is tilted in such a manner that the highest point of the base is 40 mm above the H.P. and the edge of the base on which it is resting is parallel to the V.P. Draw its projections. [15]

OR

6. A cone, having a base with a 50 mm diameter and a 70 mm long axis, is resting on one of its generators on the ground and is inclined at 30° to the V.P. Draw its projections when the apex is nearer to the V.P. than to the base. [15]

7. A hexagonal prism, having a base with a 30 mm side and a 70 mm long axis, has its face on the H.P. and the axis parallel to V.P. It is cut by a plane, which is perpendicular to VP and makes an angle of 45° with the HP bisecting the axis. Draw the sectional front view and true shape of the section. [15]

OR

8. A cone of height 60 mm and base diameter 40 mm is resting on its base on the ground. It is cut by a section plane inclined at 45° to the ground and passing through the axis of the cone at height of 20 mm from the base. Develop the lateral surface of the bottom part of the solid. [15]

9. Draw the elevation, top view and side view of the object shown in figure 1. All dimensions are in mm. [15]

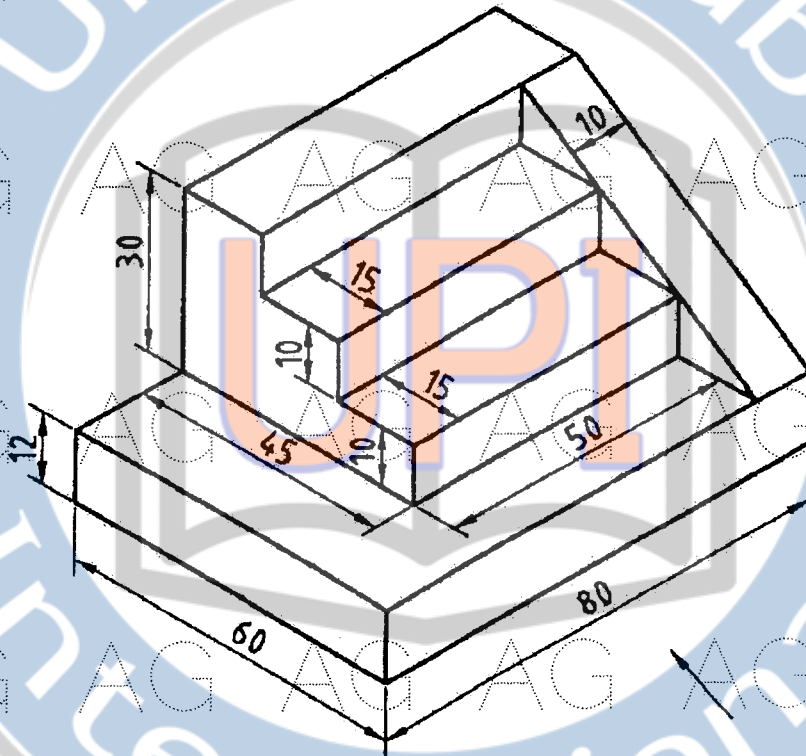

Figure: 1
OR

10. Draw the elevation, top view and side view of the object shown in figure 2. All dimensions are in mm. [15]

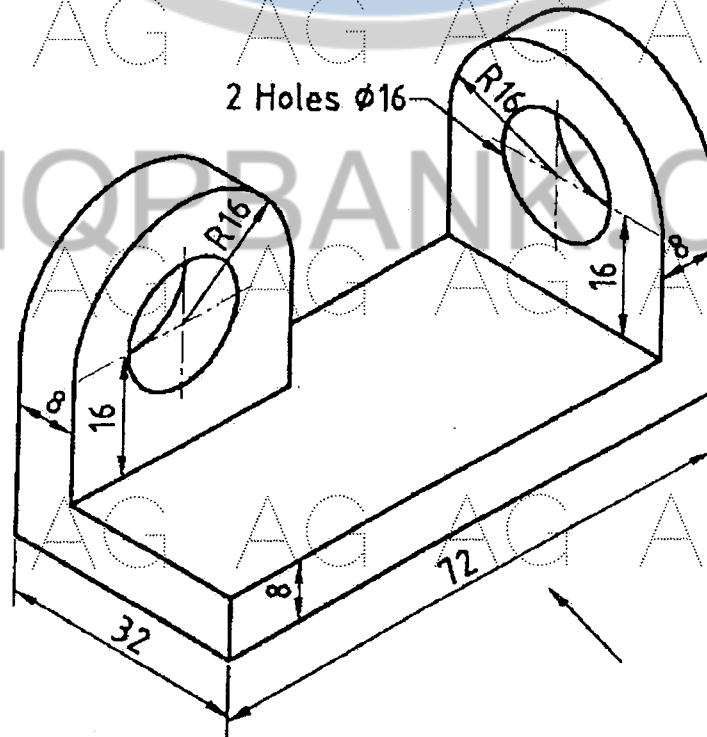

Figure: 2

---ooOoo---