

**R16**

Code No: 132AE

**JAWAHARLAL NEHRU TECHNOLOGICAL UNIVERSITY HYDERABAD**

**B.Tech I Year II Semester Examinations, April - 2018**

**ENGINEERING GRAPHICS**  
(Common to EEE, ECE, EIE)

Time: 3 hours

Max. Marks: 75

**Answer all five questions**  
**All questions carry equal marks**

---

1. The foci of an ellipse are 120 mm apart and the minor axis is 80 mm long. Determine the length of the minor axis and draw by Oblong method. Draw a curve parallel to the ellipse and 25mm away from it. [15]

OR

2. Construct a diagonal scale to read kilometers, hectometers and decameters and long enough to measure up to 6 kilometers. When a line of length 1 cm on the map represents a distance of 0.5 kilometers. Calculate the R.F and indicate a distance of 2.45 kilometers on the scale. [15]

3. A line LM 70 mm long has its end 'L' 10 mm above H.P and 15 mm in front of V.P. Its top view and front view measures 60 mm and 40 mm respectively. Draw the projections of the line and determine its inclination with H.P and V.P. [15]

OR

4. Draw the projections of a circle of 50 mm diameter resting in the H.P. on a point A on the circumference, its plane inclined at 45 degrees to the H.P and the diameter AS making 30 degrees angle with the V.P. [15]

5. A pentagonal pyramid, base 25 mm side and axis 50 mm long has one of triangular faces in the V.P. and the edge of the base contained by that face makes an angle of 30 degrees with the H.P. Draw its projections. [15]

OR

6. Draw the projections of a cylinder, base 45 mm diameter and axis 50 mm long, when it is resting on the ground on a point on its base circle with the axis making an angle of 30 degrees with H.P. and 45 degrees with the V.P. [15]

7. A cone, diameter of the base 50 mm and axis 50 mm long is resting on its base on the H.P. It is cut by a section plane perpendicular to the H.P. and passing through the apex. Draw its front view, sectional top view and true shape of the section. [15]

OR

8. A hexagonal prism of base 30 mm side is 65 mm stands on one of its rectangular faces parallel to V. P. A circular base of diameter 40 mm is drilled completely through the prism such that the axis of the hole is perpendicular to VP and bisects the axis of the prism. Draw the development of the lateral surface of the prism showing the shape of the holes formed on it. [15]

AG AG AG AG AG AG AG A

9. Draw the Isometric view of the machine parts shown below figure 1. All dimensions are in mm. [15]

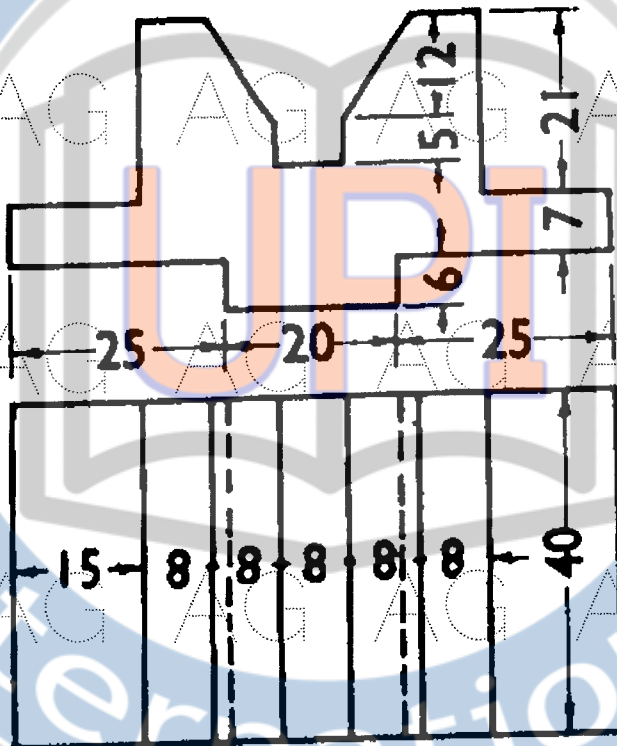

Figure: 1  
OR

10. Draw the following orthographic projections of the machine part shown below figure 2. a) Front view b) Top view c) Side view. All dimensions are in mm. [15]

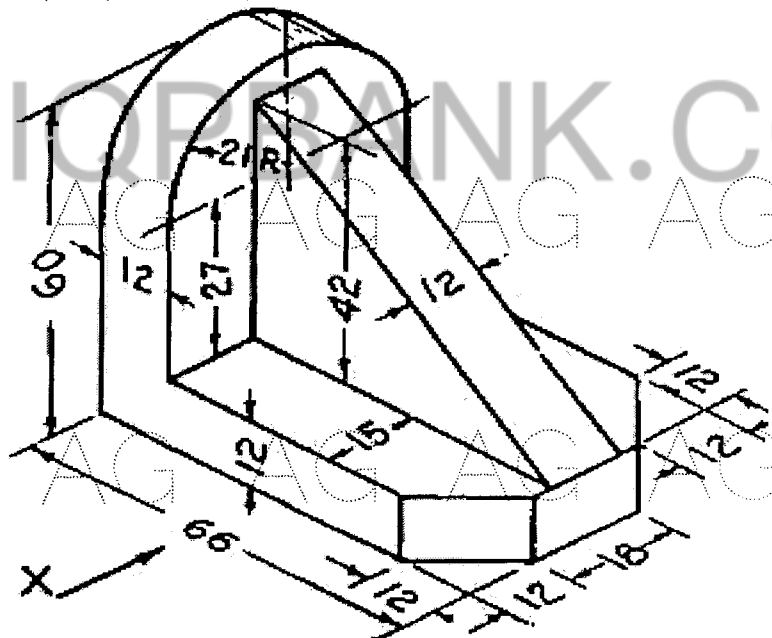

Figure: 2

AG AG AG AG AG AG AG A