

**I B. Tech II Semester Supplementary Examinations, April/May - 2018**  
**ENGINEERING DRAWING**  
(Com. to CE, ME & Textile Engg)

Time: 3 hours

Max. Marks: 70

- Note: 1. Question Paper consists of two parts (**Part-A** and **Part-B**)  
2. Answering the question in **Part-A** is Compulsory  
3. Answer any **THREE** Questions from **Part-B**
- 

**PART -A**

1. a) Divide a line of 110mm long into 15 equal parts. (3M)
- b) Draw a pentagon of side 40mm when its side is horizontal and vertical. (4M)
- c) Draw the projections of the Point C lies 30mm from the HP and 20mm from the VP. (4M)
- d) A hexagonal plane of side 40mm is resting on its corner passing through the diagonal on HP. Draw the projections. (3M)
- e) Draw the projections of a cone of diameter 30mm and 80mm long resting on HP on its apex with its axis parallel to and 40mm in front of the VP. (4M)
- f) Draw the 3-orthographic views of a regular 40mm cube with its faces mutually parallel to planes of projecting. (4M)

**PART -B**

2. a) The major axis of an ellipse is 150mm long and the minor axis is 100mm long. Find the foci and draw an ellipse by 'arcs of circles' method. Draw a tangent to the ellipse at a point on it 25mm above the major axis. (8M)
3. a) Draw the projections of the following points on the same ground line, keeping the Projectors 25mm apart. (8M)
  - i. A, in the HP and 20 mm behind the VP.
  - ii. B, 40mm above the HP and 25mm in front of the VP.
- b) Draw the projections of a 65mm long straight line, in the following positions : (8M)
  - i. Parallel to both the HP and the VP and 25mm from each.
  - ii. Perpendicular to the HP in the VP and its one end in the HP.
4. a) A regular pentagon of 25mm side has one side on the ground. Its plane is inclined at  $60^{\circ}$  to the HP. and perpendicular to the VP. Draw its projections. (8M)
- b) A line MN 50mm long is parallel to VP. and inclined at  $45^{\circ}$  to HP. The end M is 20mm above HP. and 10mm in front of VP. Draw the projections of the line. (8M)

5. a) Draw the projections of a circle of 5cm diameter, having its plane vertical and inclined at  $30^{\circ}$  to the VP. Its centre is 3cm above the HP and 2cm in front of the VP. (8M)
- b) An equilateral triangular lamina of side 30 mm is parallel to HP and perpendicular to VP. One of its sides is 20 mm in front of VP and 30 mm above HP. Draw its projections. (8M)
6. A hexagonal prism has one of its rectangular faces parallel to the HP. Its axis is perpendicular to the VP and 3.5 cm above the ground. Draw its projections when the nearer end is 2 cm in front of the VP. Side of base 2.5cm long, axis 5 cm long. (16M)
7. Draw the elevation, plan and left and right views of the part shown in the figure-1. (16M)

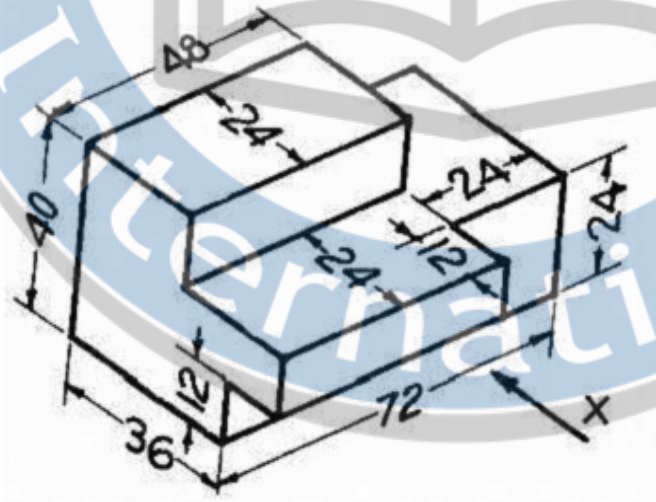

Figure-1

UPIQP.BANK.COM