

I B.Tech II Semester Supplementary Examinations, April/May - 2018
ENGINEERING DRAWING

(Com. to CSE, PCE, IT, Chem E, Aero E, Auto E, Min E, Pet E & Metal E)

Time: 3 hours

Max. Marks: 70

- Note: 1. Question Paper consists of two parts (**Part-A** and **Part-B**)
2. Answering the question in **Part-A** is Compulsory
3. Answer any **THREE** Questions from **Part-B**
- ~~~~~

PART -A

1. a) Construct a hexagon of side 40mm when two of its sides horizontal and vertical. (3M)
- b) Draw the projections of the Point A lies in the HP and 20mm away from the VP. (4M)
- c) State the quadrants with the help of drawing, in which the following point is situated: A point P; its top view is 40mm above xy; the front view 20 mm below the top view. (4M)
- d) Draw the projection of a circular lamina of diameter 25mm lying on VP and its centre 30 mm above HP. (3M)
- e) Draw the projections of a cone of diameter 30mm and 70mm long resting on HP on one its generator and parallel to the VP. (4M)
- f) Draw the 3-Orthographic views of a sphere of diameter 40mm. (4M)

PART -B

2. a) Construct an ellipse when a pair of conjugate diameters AB and CD are equal to 110mm and 50mm respectively. The angle between the conjugate diameters is 70° . (8M)
- b) A point A is 20mm above HP and in the first quadrant. Its shortest distance from the reference line XY is 40mm. Draw the projections of the point and determine its distance from VP. (8M)
3. a) A straight line PQ 100mm long is inclined at 60° to the VP and the HP. Draw its projections when one of its point P is 30mm in front of the VP. (4M)
- b) The mid point of a straight line AB is 60mm above HP and 50mm in front of VP. The line measures 80mm long and inclined at 30° to HP and 45° to VP. Draw its projections. (12M)
4. a) Draw the projections of a hexagonal plane of length of its side 30mm is in the HP and 45° to the VP. Draw its projections when the surface of the plane inclined at 60° to the VP. (10M)
- b) Draw the projections of a 60×40 rectangular plane when the plane parallel to the HP and 20mm above the HP. Its longest side is perpendicular to the VP and shortest side parallel and 30mm in front of the VP. (6M)

5. A regular pentagon of length of 40mm side, has one of its corners on VP and its surface is inclined at 60° to VP. The edge, opposite to the corner on VP, makes an angle 45° with HP. Draw the projection of the plane. (16M)
6. An equilateral triangular prism of side of base 30mm and axis 60mm long, is resting on an edge of its base on HP. The face containing that edge is inclined at 30° to HP. Draw the projections of the prism, when the edge on which the prism rests, is inclined at 60° with VP. (16M)
7. Draw the front view, top view, right and left side views of the object shown in Figure-1. (16M)

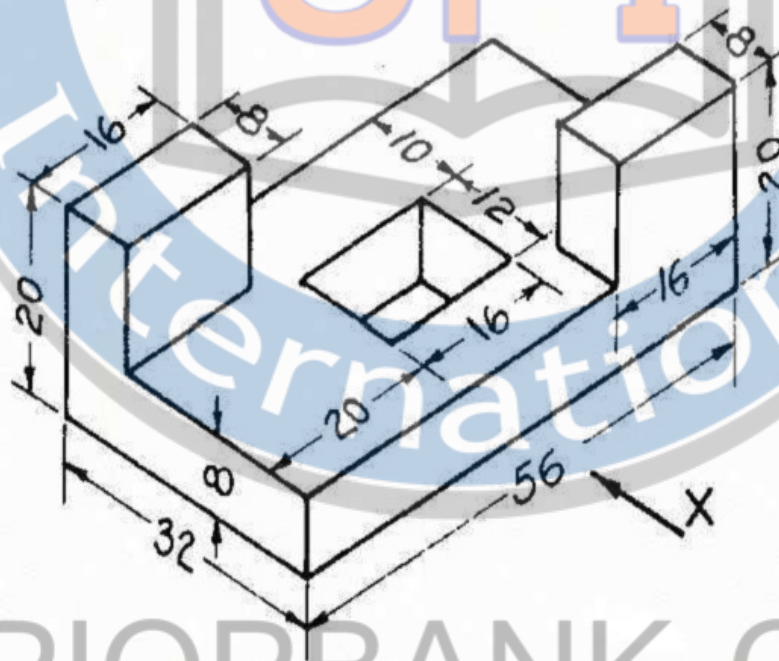

Figure-1