

Subject Code: R13109/R13

Set No - 1

I B. Tech I Semester Regular/Supplementary Examinations Jan./Feb. - 2015  
**ENGINEERING DRAWING**

(EEE)

Time: 3 hours

Max. Marks: 70

Question Paper Consists of **Part-A** and **Part-B**  
Answering the question in **Part-A** is Compulsory,  
Three Questions should be answered from **Part-B**

\*\*\*\*\*

**PART-A**

- 1.(a) Draw the Isometric view assuming suitable data: fig.1

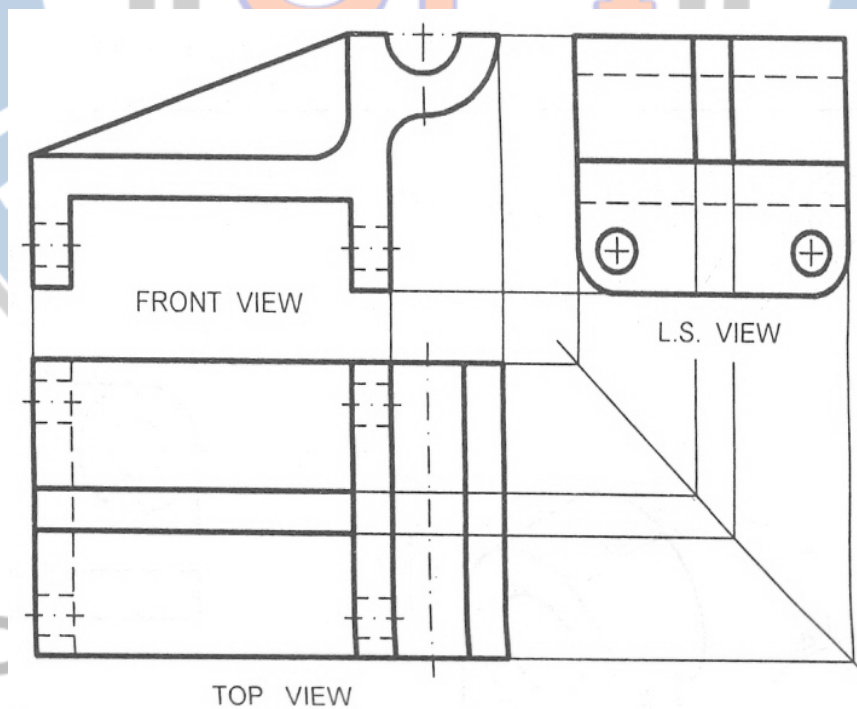

**Fig.1**

- (b) A pentagonal prism is resting on a corner of its base on the ground with a longer edge containing that corner inclined at  $45^\circ$  to the HP and the vertical plane containing that edge and the axis inclined at  $30^\circ$  to the VP. Draw its projections. Base 40 mm side, height 65 mm.

[14+8]

**PART-B**

- 2.(a) Construct a regular hexagon of side 28 mm when one side is horizontal.  
(b) An area of 144 sq cm on a map represents an area of 36 sq km on the field. Find the RF of the scale for this map and draw a diagonal scale to show kilometers, hectameters and decameters and to measure up to 10 km. Indicate on the scale a distance of 7 km, 5 hectameters and 6 decameters.

[8+8]

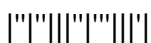

- 3.(a) The Top view of a 75 mm long line measures 55 mm. The line is in the VP, its one end being 25 mm above the HP. Draw its projections.
  - (b) Draw the projections of the following points on the same ground line, keeping the projectors 25 mm apart.
    - (i) 40 mm above the HP and 25 mm in front of the VP
    - (ii) In the VP and 40 mm above the HP
    - (iii) 15 mm above the HP and 50 mm behind the VP
- [8+8]
4. The projectors drawn from the HT and the VT of a straight line AB are 80 mm apart while those drawn from its ends are 50 mm apart. The HT is 35 mm in front of the VP, the VT is 55 mm above the HP and the end A is 10 mm above the HP. Draw the projections of AB and determine its length and inclinations with the reference planes.
- [16]
5. A semicircular plate of 80 mm diameter has its straight edge in the VP and inclined at  $45^{\circ}$  to the HP. The surface of the plate makes an angle of  $30^{\circ}$  with the VP. Draw its projections.
- [16]
6. A square headed bolt 25 mm diameter, 125 mm long and having a square neck has its axis parallel to the ground and inclined at  $45^{\circ}$  to the VP.
- [16]
7. Draw (i) Front View (ii) Top View (iii) Side View fig.2

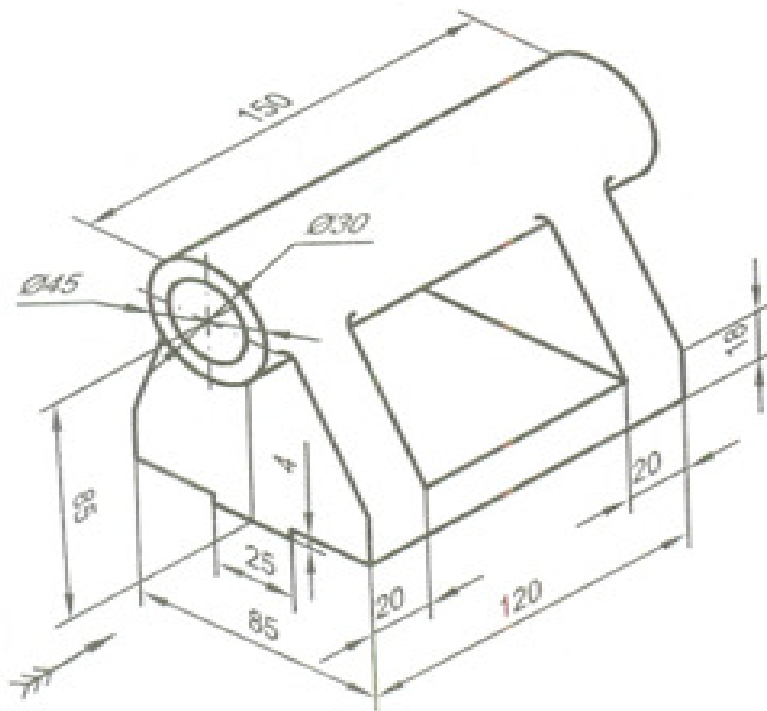
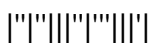

Fig.2

[16]



Subject Code: R13109/R13

Set No - 2

I B. Tech I Semester Regular/Supplementary Examinations Jan./Feb. - 2015

**ENGINEERING DRAWING**

(EEE)

Time: 3 hours

Max. Marks: 70

Question Paper Consists of **Part-A** and **Part-B**  
Answering the question in **Part-A** is Compulsory,  
Three Questions should be answered from **Part-B**

\*\*\*\*\*

**PART-A**

- 1.(a) Draw (i) Front View (ii) Top View (iii) Left Hand Side View fig.1

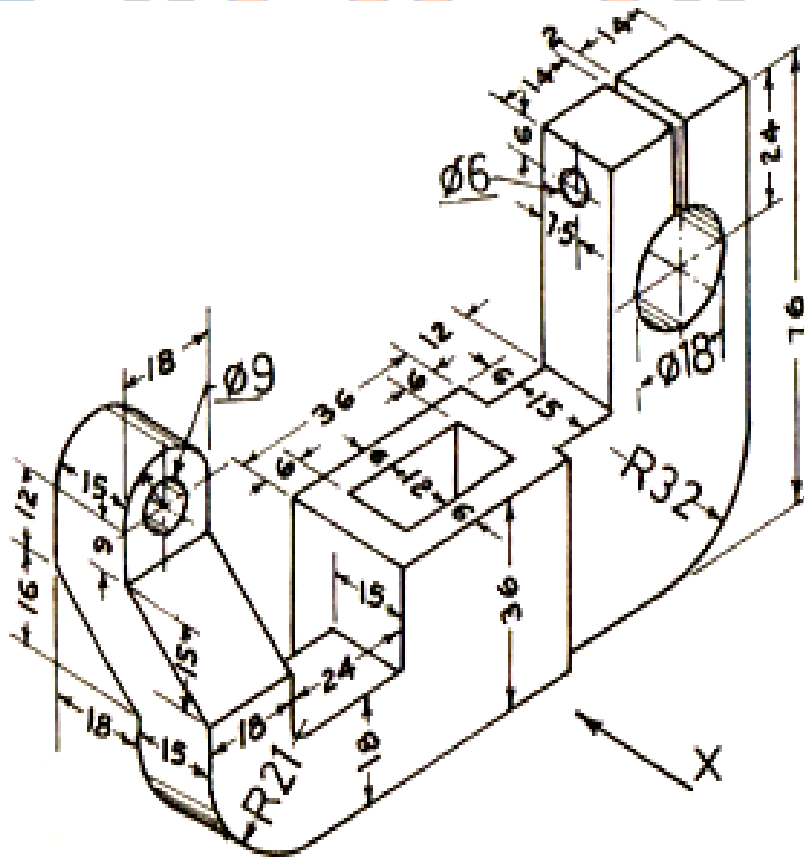

Fig.1

- (b) A square pyramid, base 40 mm side and axis 90 mm long, has a triangular face on the ground and the vertical plane containing the axis makes an angle of  $45^\circ$  with the VP. Draw its projections.

[14+8]

**PART-B**

- 2.(a) Construct a Vernier scale of RF=1/80 to read inches and to measure up to 15 yards.  
(b) A car is running at a speed of 50 km/hour. Construct a diagonal scale to show 1 Kilometer by 3 cm and to measure up to 6 kilometers. Mark also on the scale the distance covered by the car in 5 minutes 28 seconds.

[8+8]

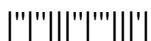

- 3.(a) Two points A and B are in the HP. The point A is 30 mm in front of the VP; While B is behind the VP. The distance between their projectors is 75 mm and the line joining their top views makes an angle of  $45^\circ$  with xy. Find the distance of the point B from the VP.
- (b) A line AB 25 mm long is parallel to VP and perpendicular to HP. Point A is 35 mm above HP and 20 mm in front of VP. Point B is 10 mm above HP. Draw the projections of the line AB. [8+8]
4. A line PQ 100 mm long is inclined at  $30^\circ$  to the HP and at  $45^\circ$  to the VP. Its midpoint is in the VP and 20 mm above the HP. Draw its projections, if its end P is in the third quadrant and Q in the first quadrant. [16]
5. Draw an equilateral triangle of 75 mm side and inscribe a circle in it. Draw the projection of the figure, when its plane is vertical and inclined at  $30^\circ$  to the VP and one of the sides of the triangle is inclined at  $45^\circ$  to the HP. [16]
6. Draw the projections of a cylinder, base 30 mm diameter and axis 40 mm long, resting with a point of its base circle on HP such that the axis is making an angle of  $30^\circ$  with HP and parallel to VP. [16]
7. Draw the Isometric view: fig.2 [16]

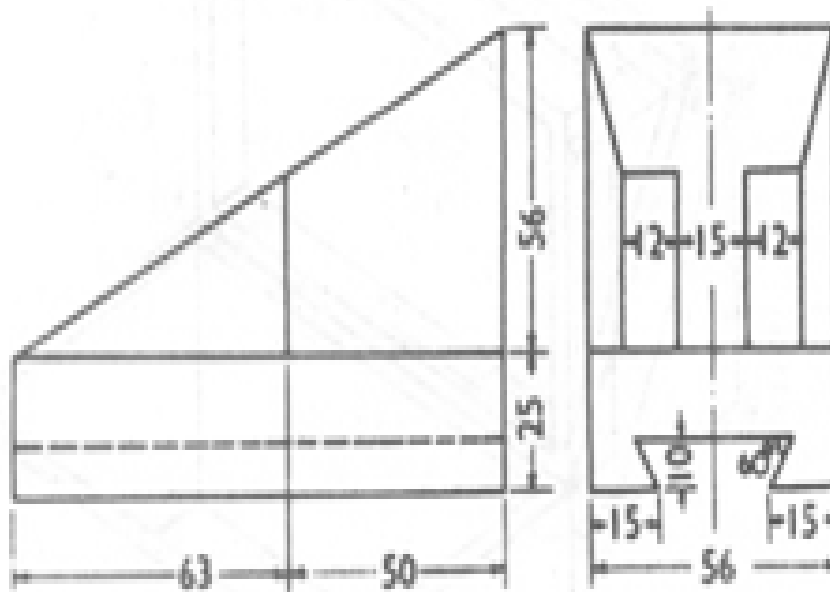

**Fig.2**

[16]

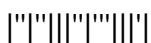

Subject Code: R13109/R13

Set No - 3

I B. Tech I Semester Regular/Supplementary Examinations Jan./Feb. - 2015

**ENGINEERING DRAWING**

(EEE)

Time: 3 hours

Max. Marks: 70

Question Paper Consists of **Part-A** and **Part-B**  
Answering the question in **Part-A** is Compulsory,  
Three Questions should be answered from **Part-B**

\*\*\*\*\*

**PART-A**

- 1.(a) Draw the Isometric view: fig.1

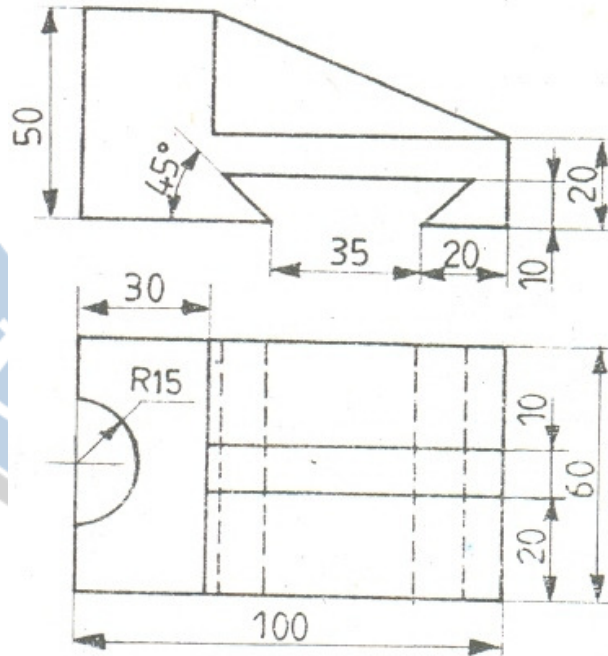

**Fig.1**

- (b) A cylindrical block, 75 mm diameter and 25 mm thick, has a hexagonal hole of 25 mm side, cut centrally through its flat faces. Draw three views of the block when it has its flat faces vertical and inclined at  $30^\circ$  to the VP and two faces of the hole parallel to the HP.

[14+8]

**PART-B**

- 2.(a) Construct a regular polygon of any number of sides, given the length of its sides equal to 25 mm.  
(b) The actual length of 500 m is represented by a line of 15 cm on a drawing. Construct a vernier scale to read upto 600 m. Mark on the scale a length of 549 m.
- 3.(a) A vertical line AB, 75mm long, has its end A in the HP and 25 mm in front of the VP. A line AC, 100 mm long, is in the HP and parallel to the VP. Draw the projections of the line joining B and C, and determine its inclination with the HP.  
(b) A line CD 30 mm long is parallel to both the planes. The line is 40 mm above HP and 25 mm in front of VP. Draw its projections.

[8+8]

[8+8]

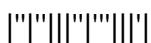

- 4. A line AB, 65 mm long, has its end A in the HP and 15 mm in front of the VP. The end B is in the third quadrant. The line is inclined at  $35^\circ$  to the HP and at  $60^\circ$  to the VP. Draw its projections. [16]
- 5. A  $60^\circ$  Set-square of 125 mm longest side is so kept that the longest side is in the HP making an angle of  $30^\circ$  with the VP and set square itself inclined at  $45^\circ$  to the HP. Draw the projections of the Set-square. [16]
- 6. A hexagonal pyramid, base 25mm side and axis 50mm long, has on edge of its base on the ground. Its axis is inclined at  $30^\circ$  to the ground and parallel to the VP. Draw its projections. [16]
- 7. Draw (i) Front View (ii) Top View (iii) Side View fig.2 [16]

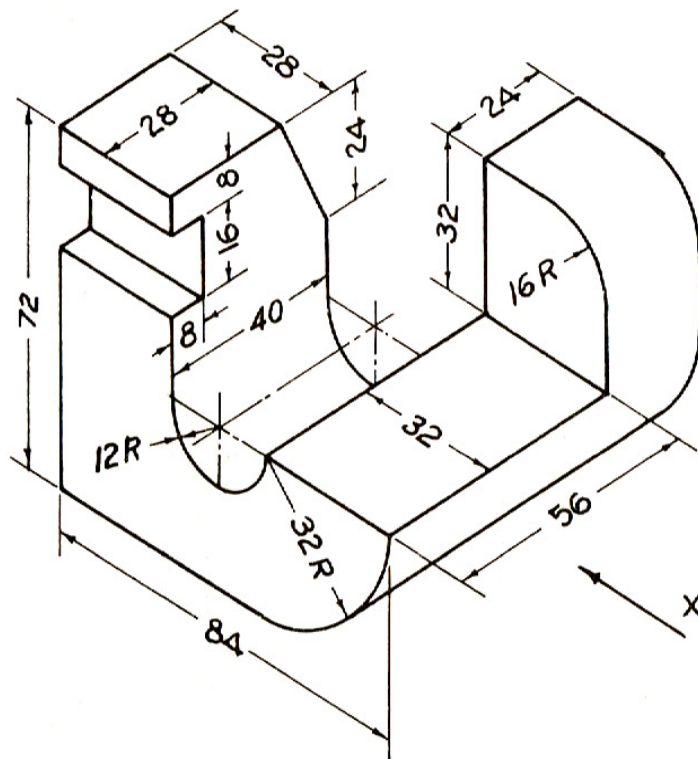
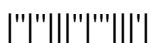

Fig.2

[16]



Subject Code: R13109/R13

Set No - 4

I B. Tech I Semester Regular/Supplementary Examinations Jan./Feb. - 2015  
**ENGINEERING DRAWING**

(EEE)

Time: 3 hours

Max. Marks: 70

Question Paper Consists of **Part-A** and **Part-B**  
Answering the question in **Part-A** is Compulsory,  
Three Questions should be answered from **Part-B**

\*\*\*\*\*

**PART-A**

- 1.(a) Draw (i) Front View (ii) Top View (iii) Left Hand Side View fig.1

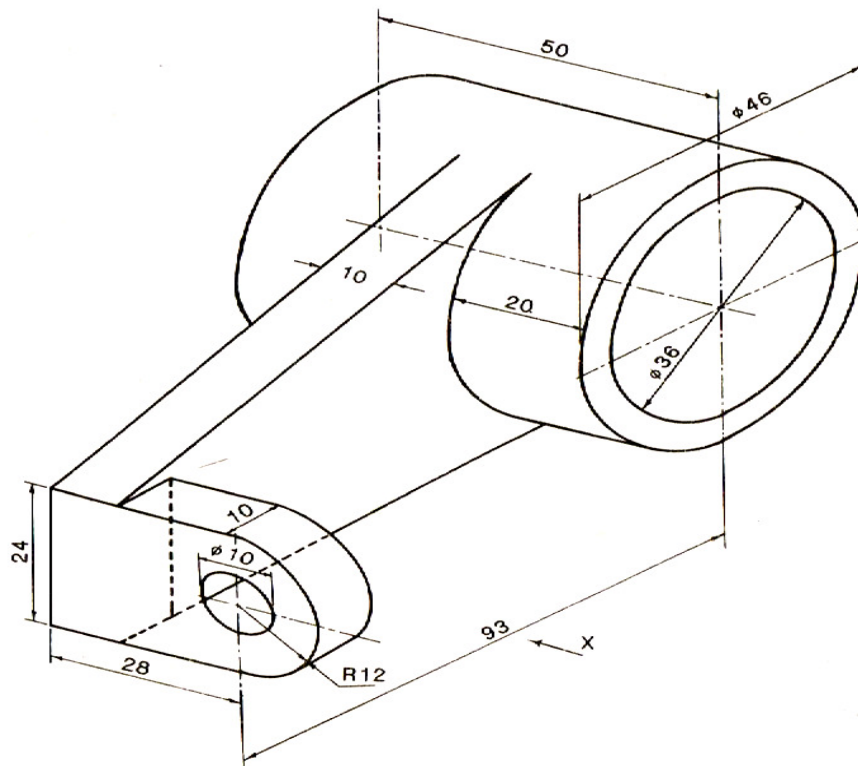

**Fig.1**

- (b) The top view of a plate, the surface of which is perpendicular to the VP and inclined at  $60^\circ$  to the HP is a circle of 60 mm diameter. Draw its three views.

[14+8]

**PART-B**

- 2.(a) Draw an Octagon given the length of side 25 mm.  
(b) The major axis of an ellipse is 100 mm and the minor axis 55 mm. Find the foci and construct the ellipse by Intersecting Arcs method.
- 3.(a) A point 30 mm above xy line is the plan view of two points P and Q. The elevation of P is 45 mm above the HP. While that of the point Q is 35 mm below the HP. Draw the projections of the points and state their position with reference to the principle planes and the quadrant in which they lie.

[8+8]

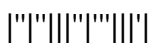

- 3.(b) A line PQ 40 mm long is parallel to VP and inclined at an angle of  $30^\circ$  to HP. The lower end P is 15 mm above HP and 20 mm in front of VP. Draw the projections of the line. [8+8]
- 4. The top view of a 75 mm long line AB measures 65 mm, while the length of its front view is 50 mm. It's one end A is in the HP and 12 mm in front of the VP. Draw the projections of the AB and determine its inclinations with the HP and the VP. [16]
- 5. A thin circular plate of 70 mm diameter is resting on its circumference such that its plane is inclined  $60^\circ$  to the HP and  $30^\circ$  to the VP. Draw the projections of the plane. [16]
- 6. A right circular cone of base diameter 50 mm and height 60 mm is placed such that one diameter AB of the base is inclined at  $45^\circ$  to HP and the other diameter CD of the base is parallel to both HP and VP. The diameters AB and CD are perpendicular to each other. Draw the projections of the cone. [16]
- 7. Draw the Isometric view: fig.2 [16]

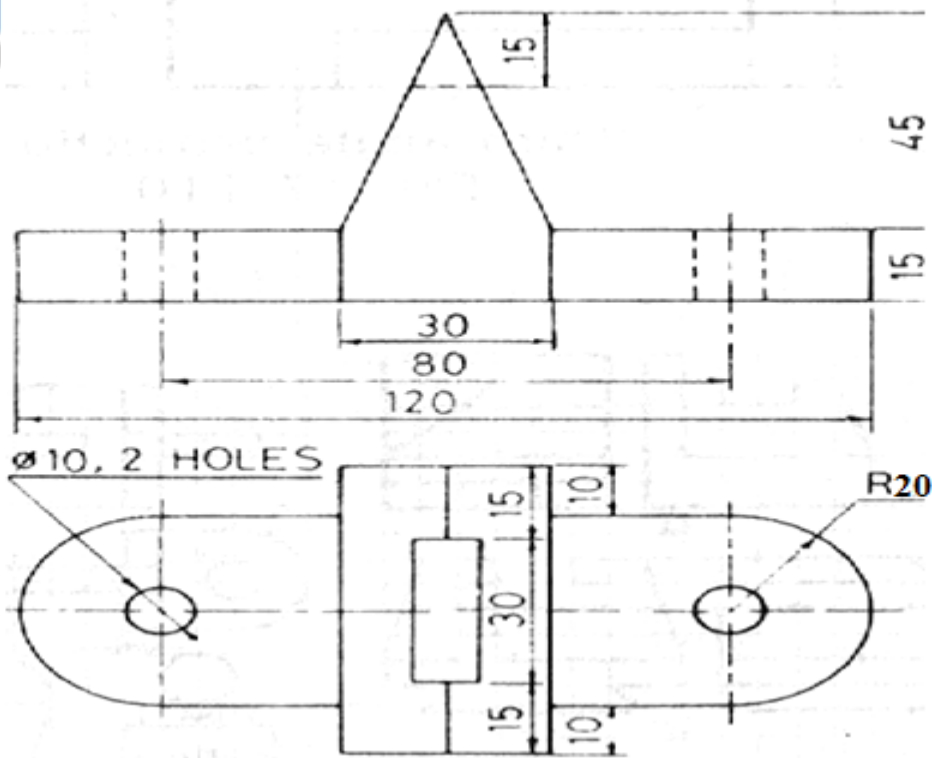

Fig.2

[16]

