

ENGINEERING MECHANICS

(Civil Engineering)

Time: 3 hours

Max. Marks: 70

PART – A
(Compulsory Question)

- 1 Answer the following: (10 X 02 = 20 Marks)
- Explain the principle of transmissibility of force with simple schematic sketches.
 - Draw the free body diagram for a system in which a cylinder is kept inside the V-groove.
 - What are wedges?
 - What is the condition for a screw jack to be of self-locking?
 - State the parallel axis theorem.
 - What is inertia?
 - Draw the motion curves for constant acceleration.
 - Write the expressions for normal and tangential components of acceleration.
 - What is a perfect frame?
 - Define the simple harmonic motion.

PART – B
(Answer all five units, 5 X 10 = 50 Marks)

UNIT – I

- 2 Two identical rollers, each of weight $W = 1000\text{ N}$, are supported by an inclined plane and a vertical wall as shown in figure below. Find the reactions at the points of supports A, B and C. Assume all the surfaces to be smooth.

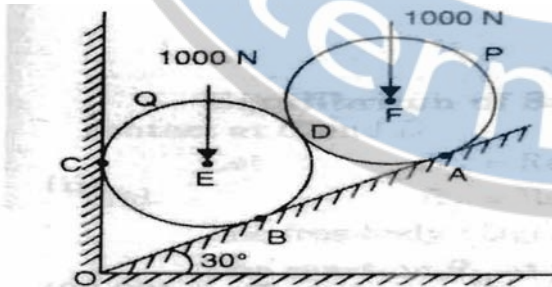

OR

- 3 A beam AB 1.7 m long is loaded as shown in figure below. Determine the reactions at A and B.

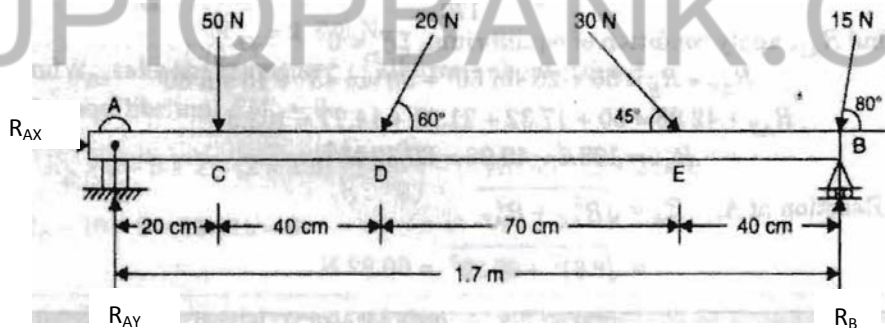

UNIT – II

- 4 A pull of 20 N, inclined at 25° to the horizontal plane, is required just to move a body placed on a rough horizontal plane. But the push required to move the body is 25 N. If the push is inclined at 25° to the horizontal, find the weight of the body and co-efficient of friction.
- OR
- 5 The efficiency of a screw jack is 55%, when a load of 1500 N is lifted by an effort applied at the end of a handle of length 50 cm. Determine the effort applied if the pitch of the screw thread is 1 cm.

UNIT - III

6 Find the center of gravity of the section given in the figure below.

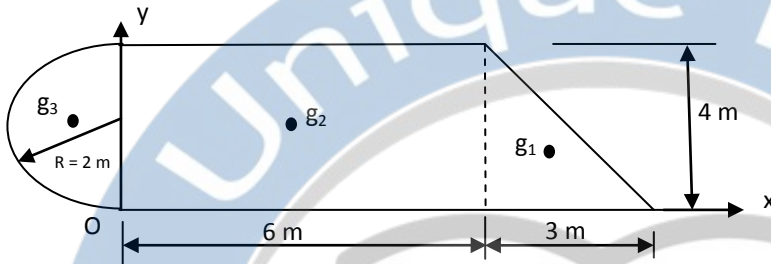

OR

7 Find the moment of inertia of the area shown shaded in figure given below, about the edge AB.

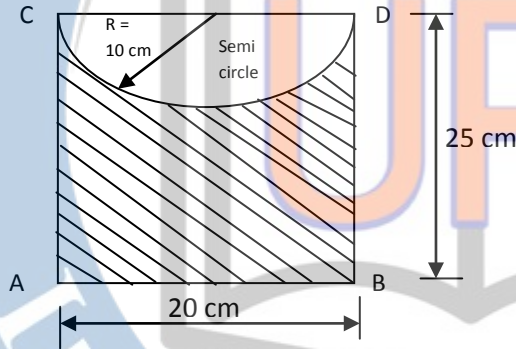

UNIT - IV

8 A particle is dropped from the top of a tower 100 m high. Another particle is projected upwards at the same time from the foot of the tower and meets the first particle at a height of 30 m. Find the velocity with which the second particle is projected upwards. Take $g = 9.8 \text{ m/s}^2$.

OR

9 A car, moving on a straight level road, skidded for a total distance of 60 meters after the brakes were applied. Determine the speed of the car, just before the brakes were applied, if the coefficient of friction between the car tyres and the road is 0.4. Take $g = 9.8 \text{ m/s}^2$.

UNIT - V

10 Determine the forces in the truss shown in figure below, which carries a horizontal load of 12 kN and a vertical load of 18 kN.

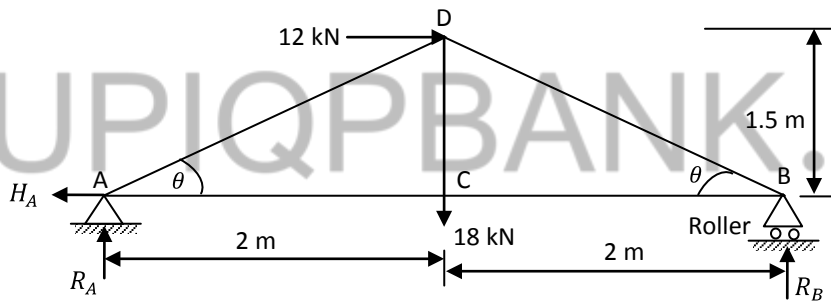

OR

11 A truss of span 9 m is loaded as shown in figure below. Find the reactions and forces in the members marked 1, 2 and 3.

